

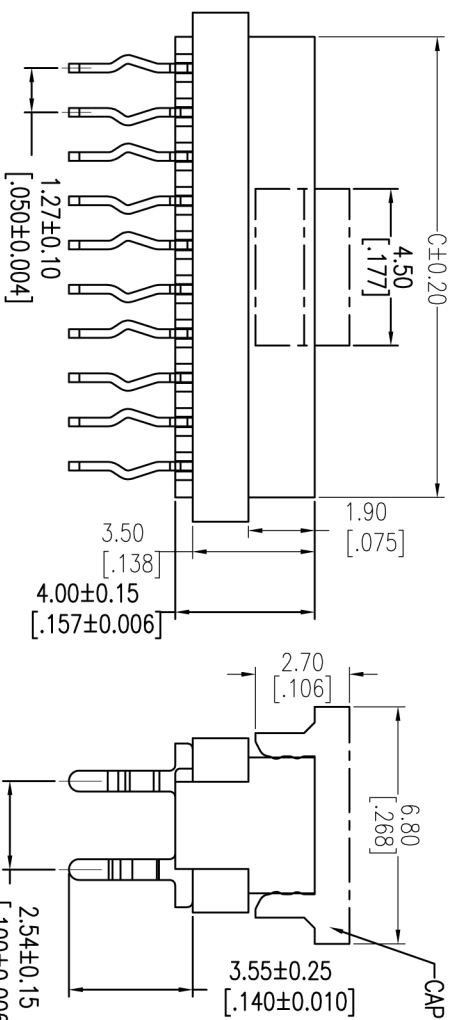

Recommended P.C.B Layout(Top Side)  
(PCB BOARD TOLERANCE±0.05)

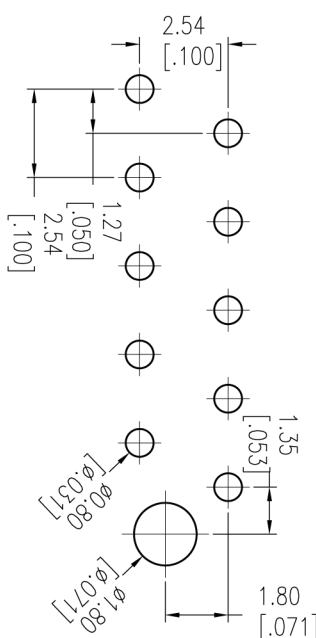
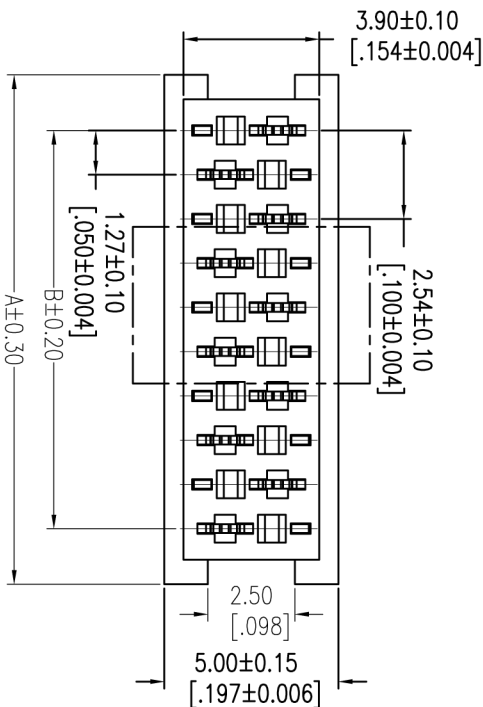

## Ordering Information

3900-XX FS SN E N X 01

No. of Pins  
04P 12P  
06P 14P  
08P 16P  
10P 18P  
20P

Contact Plating  
SN=Tin  
E=P/A46

Insulator Material  
E=P/A46

Packing  
T=Tube  
P=Tube+CAP

### NOTES:

Current Rating: 1.0AMP  
Contact Resistance: 20mΩ Max  
Withstand Voltage: 500V AC/DC  
Insulation Resistance: 1000MΩ Min  
Operation Temperature: -40°C to +105°C  
Contact Material: Phosphor Bronze  
Contact plating: Sn Over Ni  
Insulator Material: PA46+30%G.F UL94V-0

### Specification & Ordering Information:

Circuit	Part No.	Dimension			Qty /Tube
		A	B	C	
04	3900-04FSSNENX01	7.00	3.81	5.60	82
06	3900-06FSSNENX01	9.54	6.35	8.14	60
08	3900-08FSSNENX01	12.08	8.89	10.68	48
10	3900-10FSSNENX01	14.62	11.43	13.22	39
12	3900-12FSSNENX01	17.16	13.97	15.76	33
14	3900-14FSSNENX01	19.70	16.51	18.30	29
16	3900-16FSSNENX01	22.24	19.05	20.84	26
18	3900-18FSSNENX01	24.78	21.59	23.38	23
20	3900-20FSSNENX01	27.32	24.13	25.92	21

PART NO. SEE TAB

TITLE: Mini Match Socket 180° DIP  
Without Socket Without Latch



上海回峰电子科技有限公司  
Shanghai Hui Feng Electronic Technology Co., Ltd.

电话: 021-67150229  
传真: 021-67150251  
企业邮箱: hui Feng\_dzki@163.com  
公司网站: www.hui Feng-china.com

REV	DATE	MODIFICATION DESCRIPTION	CHANGE	OPERATION	DRAW	DATE	SCALE	FIT	PART NO.
A2	2014/05/28	Micro Match --Mini Match		XX ±0.40	JYhuang	2014/05/28	UNIT	mm	SEE TAB
A0	2012/10/11	NEW		XXX ±0.25	CHECK	DATE	SIZE	A4	TTITLE: Mini Match Socket 180° DIP Without Socket Without Latch
				XXXX ±0.15	CHECK	DATE	SHEET	1/1	Customer NO.
				Angle ± 3'	APPROVE	DATE	PROJ.		

OPERATION	DRAW	DATE	SCALE	FIT	PART NO.
XX ±0.40	JYhuang	2014/05/28	UNIT	mm	SEE TAB
XXX ±0.25	CHECK	DATE	SIZE	A4	TTITLE: Mini Match Socket 180° DIP Without Socket Without Latch
XXXX ±0.15	CHECK	DATE	SHEET	1/1	Customer NO.
Angle ± 3'	APPROVE	DATE	PROJ.		

OPERATION	DRAW	DATE	SCALE	FIT	PART NO.
XX ±0.40	JYhuang	2014/05/28	UNIT	mm	SEE TAB
XXX ±0.25	CHECK	DATE	SIZE	A4	TTITLE: Mini Match Socket 180° DIP Without Socket Without Latch
XXXX ±0.15	CHECK	DATE	SHEET	1/1	Customer NO.
Angle ± 3'	APPROVE	DATE	PROJ.		

OPERATION	DRAW	DATE	SCALE	FIT	PART NO.
XX ±0.40	JYhuang	2014/05/28	UNIT	mm	SEE TAB
XXX ±0.25	CHECK	DATE	SIZE	A4	TTITLE: Mini Match Socket 180° DIP Without Socket Without Latch
XXXX ±0.15	CHECK	DATE	SHEET	1/1	Customer NO.
Angle ± 3'	APPROVE	DATE	PROJ.		

OPERATION	DRAW	DATE	SCALE	FIT	PART NO.
XX ±0.40	JYhuang	2014/05/28	UNIT	mm	SEE TAB
XXX ±0.25	CHECK	DATE	SIZE	A4	TTITLE: Mini Match Socket 180° DIP Without Socket Without Latch
XXXX ±0.15	CHECK	DATE	SHEET	1/1	Customer NO.
Angle ± 3'	APPROVE	DATE	PROJ.		

OPERATION	DRAW	DATE	SCALE	FIT	PART NO.
XX ±0.40	JYhuang	2014/05/28	UNIT	mm	SEE TAB
XXX ±0.25	CHECK	DATE	SIZE	A4	TTITLE: Mini Match Socket 180° DIP Without Socket Without Latch
XXXX ±0.15	CHECK	DATE	SHEET	1/1	Customer NO.
Angle ± 3'	APPROVE	DATE	PROJ.		