

HSF

NOTES:

Current Rating:1.0AMP
 Contact Resistance:30mΩ max
 Withstand Voltage:500V AC/DC
 Insulation Resistance:1000MΩ min
 Operation Temperature:-40°C to +105°C

Contact Material:Phosphor Bronze
 Contact plating:Au Or Sn over Ni
 Insulator Material:Body:LCP+30%G.F UL94V-0
 Cover:PBT+30%G.F UL94V-0

Ordering Information

5243-XX Y P XX B X 01

No. of Pins Contact Plating Δ Insulator Shape
 S0=Gold Flash/Tin W:With Bump
 S3=10u"Gold/Tin N:Without Bump
 S4=15u"Gold/Tin
 S5=30u"Gold/Tin
 SN=Tin

Item	Pitch	Mating
Standard	1.27X2.54	3144
Alternate		

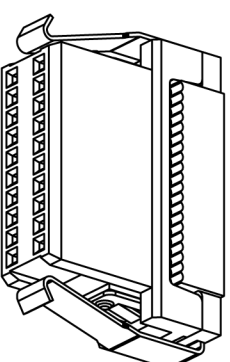
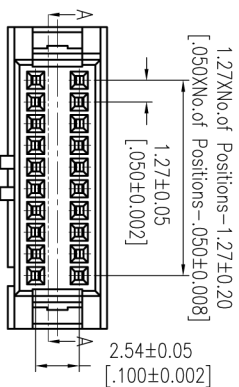
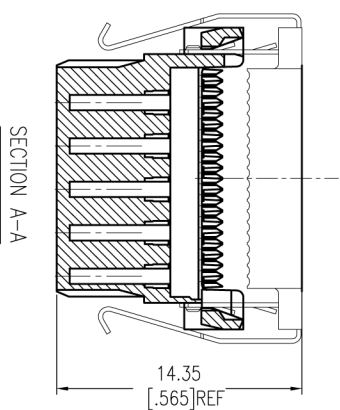
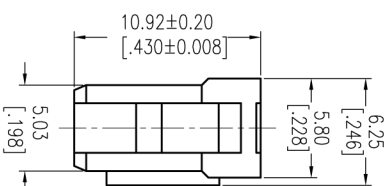
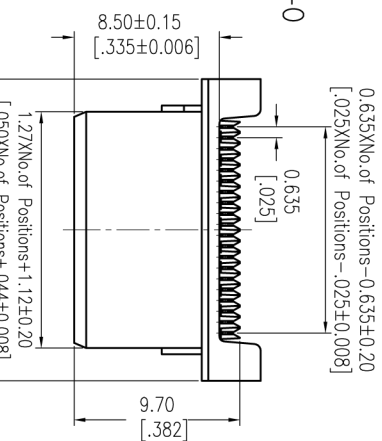
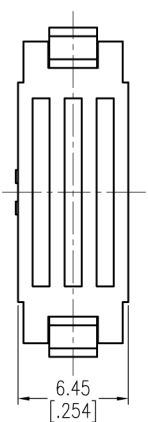
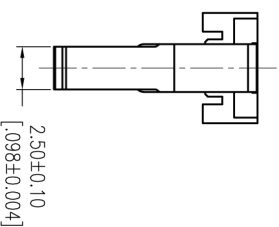
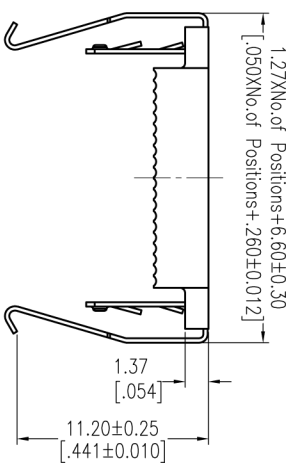

REV	DATE	MODIFICATION DESCRIPTION	CHANGE	OPERATION	DRAW	DATE	SCALE	FIT	PART NO.
A1	2013/08/12	Modify the Plated Gold/Ni to Gold/Tin	Δ	XX ±0.40	TsingSn	2013/08/12	UNIT	mm	5243-XXYPXXBX01
A0	2012/10/10	NEW		X.XX ±0.25	CHECK	DATE	SIZE	A4	TITLE: 1.27*2.54mm IDC WITH LATCH
				X.XXX ±0.15	CHECK	DATE	SHEET	1/1	Customer NO.
				Angle ± 3°	APPROVE	DATE	PROJ.		
				DIM TOL					

hf 上海回峰电子科技有限公司
 Shanghai Hui Feng Electronic Technology Co., Ltd.
 电话: 021-67150229
 传真: 021-67150251
 企业邮箱: hui Feng_dzki@163.com
 公司网站: www.huifeng-china.com