

HSF

NOTES:

Current Rating: 3.0AMP
 Contact Resistance: 20mΩ Max
 Withstand Voltage: 1000V AC/DC
 Insulation Resistance: 1000MΩ Min
 Operation Temperature: -40°C to +105°C

Contact Material: Brass
 Contact plating: Au Or Sn over Ni
 Insulator Material: PA9T+30%G.F UL94V-0(Std)
 Or PBT+30%G.F UL94V-0

Ordering Information

3110-XX R XX B K00 XX

No. of Pins	Contact Plating	Color Insulator	Packing:
6P 24P	G0=Gold Flash	B=Black	A=Tray
8P 26P	G3=10u"Gold	U=blue	T=Tube
10P 30P	G4=5u"Gold	G=Gray(427C)	
12P 34P	G5=30u"Gold	E=Gray(413C)	
14P 40P	S0=Gold Flash/Tin		
16P 50P	S3=10u"Gold/Tin		
18P 60P	S4=5u"Gold/Tin		
20P 64P	S5=30u"Gold/Tin		
	SN=Tin		

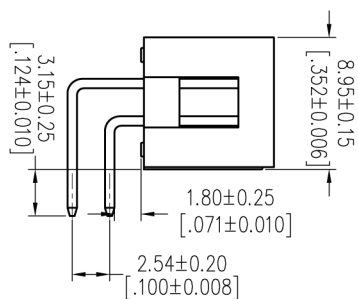
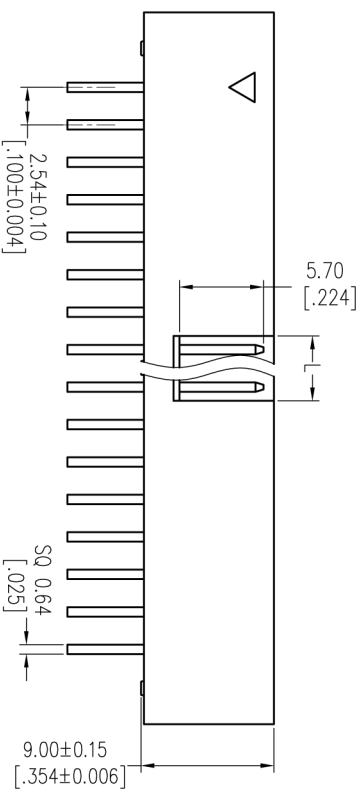
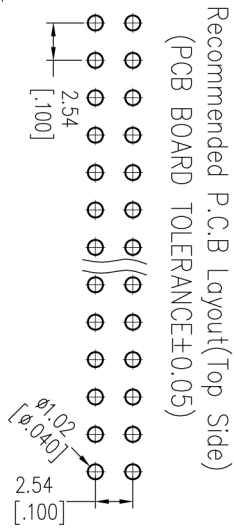
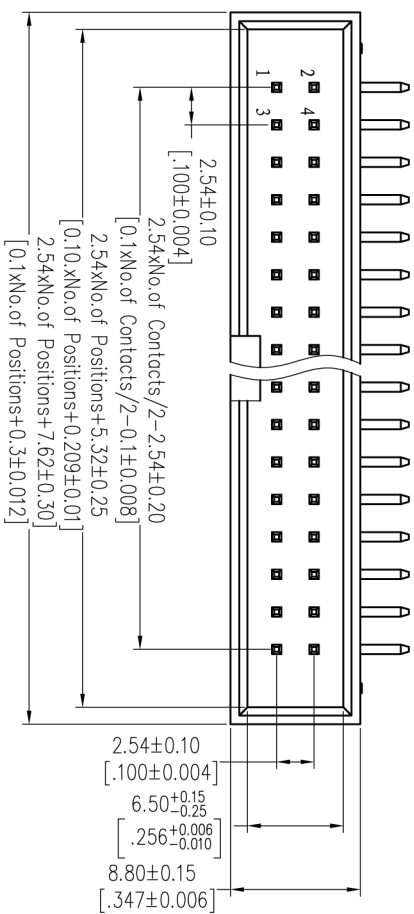

Dimension antitheses list	
NO. Pin	L
6P-8P	4.00
10P-64P	4.40

Item	Pitch	Mating
Standard	2.54	5212/2185
Alternate		

OPERATION		DRAW		DATE		SCALE		PART NO.	
XX	±0.40	JYHuang		2012/09/25		mm		3110-XXXXXXBK00XX	
XX	±0.25	CHECK		DATE		A4		TITLE: 2.54 BOX HEADER 90° H=9.0	
X.XXX	±0.15	APPROVE		DATE		1/1		Customer NO.	
Angle	± 3'								
DIM	TOL								
CHANGE									
A0	2012/09/25	NEW							
REV	DATE	MODIFICATION DESCRIPTION							

hf 上海回峰电子科技有限公司
 Shanghai Hui Feng Electronic Technology Co., Ltd.

电话: 021-67150229
 传真: 021-67150251
 企业邮箱: huiheng_dzkj@163.com
 公司网站: www.huiheng-china.com