



NOTES:

Current Rating: 2.0AMP
 Contact Resistance: 20mΩ Max
 Withstand Voltage: 500V AC/DC
 Insulation Resistance: 1000MΩ Min
 Operation Temperature: -40°C to +105°C

Contact Material: Phosphor Bronze
 Contact plating: Au Or Sn over Ni
 Insulator Material: PA9T+30%G.F UL94V-0

Ordering Information

2272 - 2 XX R XX CUNT 1

No. of Pins per ROW: 52-40PIN

Contact Plating:
 G0=Gold Flash
 G3=10μ"Gold
 G4=15μ"Gold
 G5=30μ"Gold
 S0=Gold Flash/Tin
 S3=10μ"Gold/Tin
 S4=15μ"Gold/Tin
 S5=30μ"Gold/Tin
 SN=Sn
 SM=Mate Tin

Packing:
 T=Tube

Item	Pitch	Mating
Standard	2.00	1215/1220
Alternate		

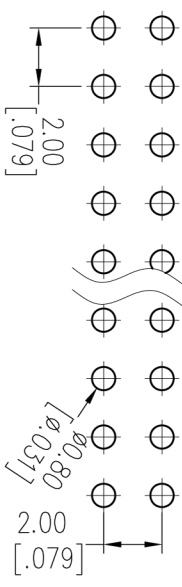
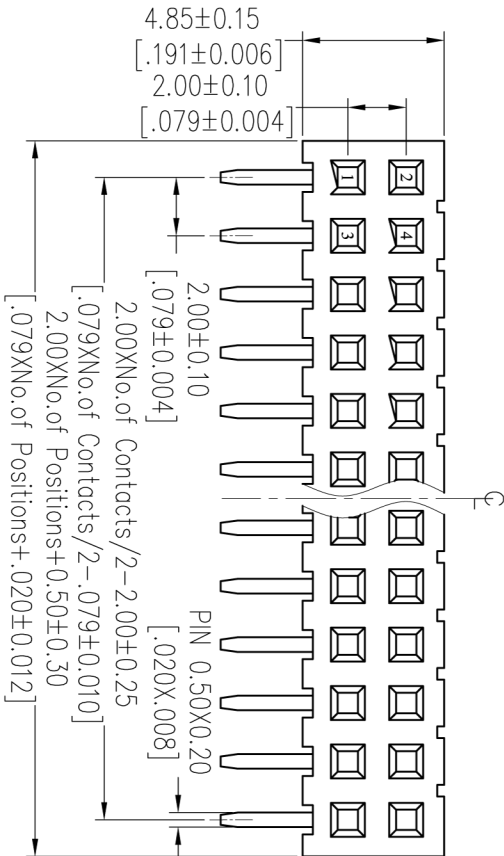
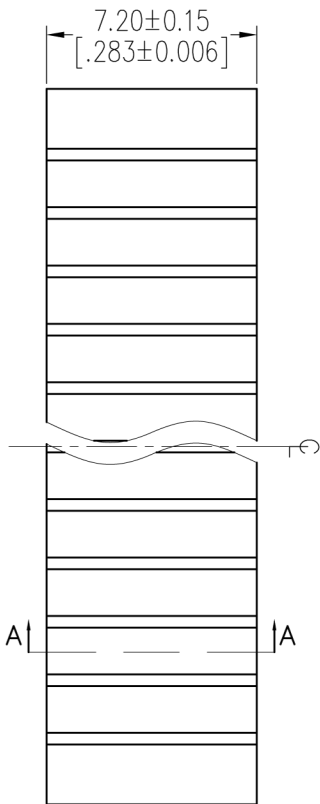

Recommended P.C.B. Layout (Top Side)
 (PCB BOARD TOLERANCE±0.05)

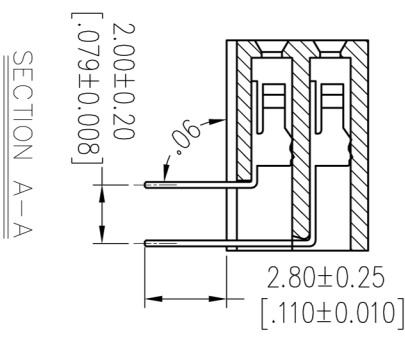

REV	DATE	MODIFICATION DESCRIPTION
A0	2012/07/19	NEW

OPERATION	DRAW	DATE
XX ±0.40	JYhuang	2012/07/19
XXX ±0.25	CHECK	DATE
XXXX ±0.15	APPROVE	DATE
Angle ± 3'	APPROVE	DATE
DIM TOL		

SCALE	FIT	PART NO.
UNIT	mm	2272-2XXXXXCUNT1
SIZE	A4	TITLE: FH2.00mm DUAL ROW 90° DIP H=7.20
SHEET	1/1	Customer NO.



上海回峰电子科技有限公司
 Shanghai Hui Feng Electronic Technology Co., Ltd.
 电话: 021-67150229
 传真: 021-67150251
 企业邮箱: huiheng_dzki@163.com
 公司网站: www.huiheng-china.com